

MS® Deadbolt

For Aluminum Stile Doors - 1" x 6-7/8" Faceplate

MS1850S Series

ANSI/BHMA Type E8211 (Grade 1)

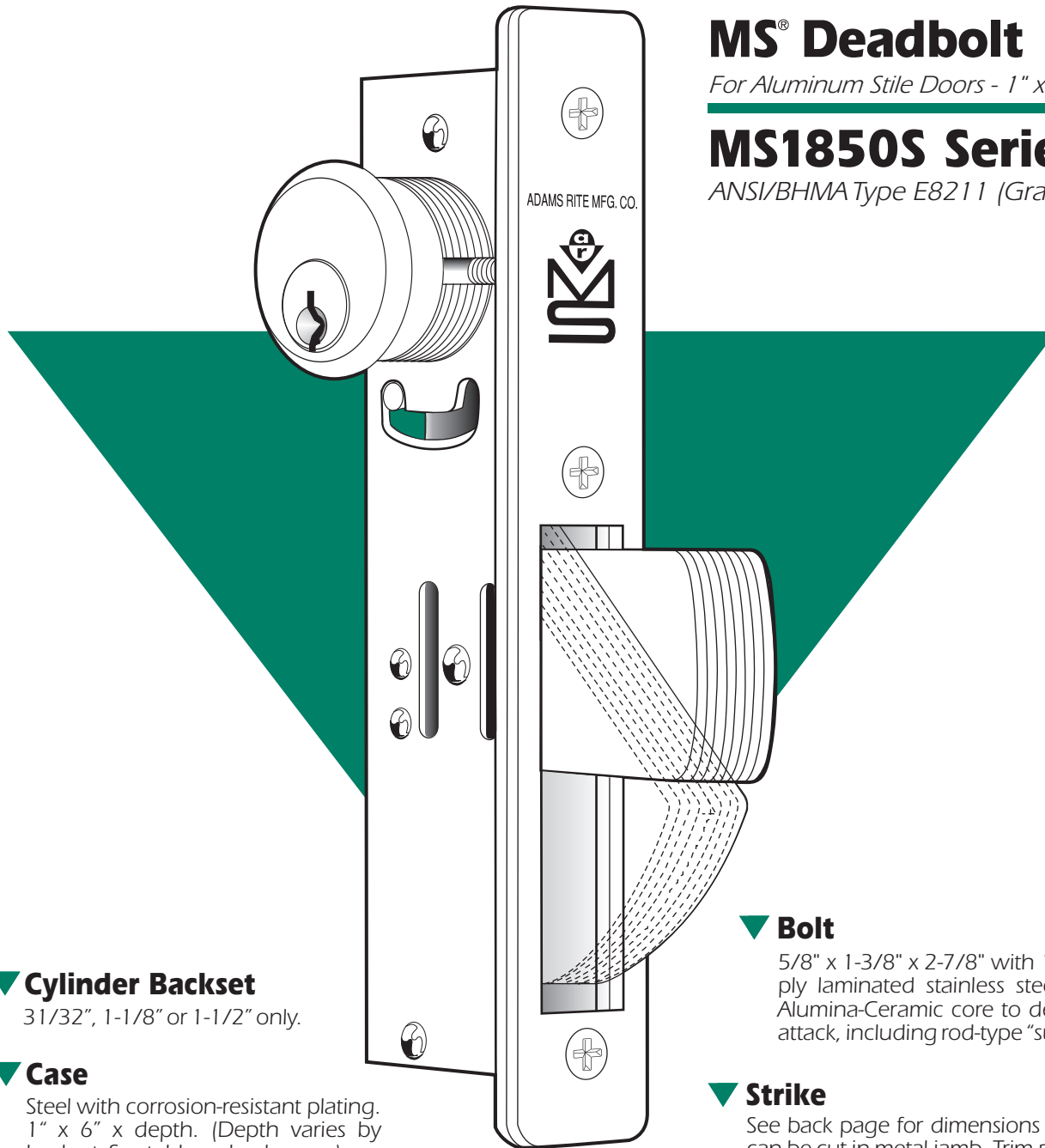

▼ Cylinder Backset

31/32", 1-1/8" or 1-1/2" only.

▼ Case

Steel with corrosion-resistant plating. 1" x 6" x depth. (Depth varies by backset. See table on back page.)

▼ Function

A huge bolt of laminated stainless steel, nearly three inches long, activated by an uncomplicated pivot mechanism, has made this basic MS® Deadbolt the standard of the narrow stile door industry. The length of this bolt provides maximum security for a single leaf door, even a very tall and flexible one or an installation where the gap between door and jamb is greater than it should be.

▼ Bolt

5/8" x 1-3/8" x 2-7/8" with 1-3/8" throw. Eight ply laminated stainless steel. Center ply has Alumina-Ceramic core to defeat any hacksaw attack, including rod-type "super" hacksaws.

▼ Strike

See back page for dimensions of strike slot which can be cut in metal jamb. Trim plate, box strike and armored strike are also available. (See page SW-16.)

▼ Operation

360° turn of key or thumbturn throws or retracts the counterbalanced bolt. Key can be removed only when bolt is in a positively locked or unlocked position. Lock accepts any standard 1-5/32" diameter mortise cylinder or thumbturn from either or both sides. Cylinder must have MS® dimensioned cam. (See page SW-33.)



MS 1850S Deadbolt

DIMENSIONS

INCHES
MILLIMETERS
Nominal, subject to tolerance extremes.

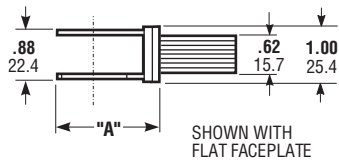

SHOWN WITH
FLAT FACEPLATE

BACKSET	"A"
31/32" 24.6	1.63 41.4
1-1/8" 28.6	1.78 45.2
1-1/2" 38.1	2.25 57.1

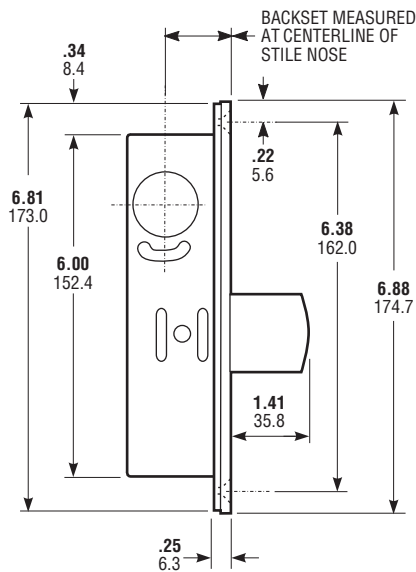

BACKSET MEASURED
AT CENTERLINE OF
STILE NOSE

ARMORED FACEPLATE 1" x 6-7/8"	
FLAT	MS1850S
RADIUS	MS1851S
RADIUS w/WEATHERSTRIP	MS1851SW
LH BEVEL	MS1852S-015
RH BEVEL	MS1852S-016

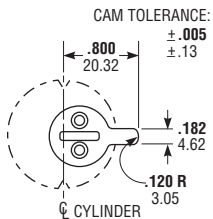

Cylinder Cam

MS1850S Series locks are operable by any standard 1-5/32" diameter mortise cylinder with special MS® cam dimensioned as shown. Cylinders with MS® cams can be readily obtained from most cylinder manufacturers. See page SW-33 for cylinder make and trim ring information.

INSTALLATION

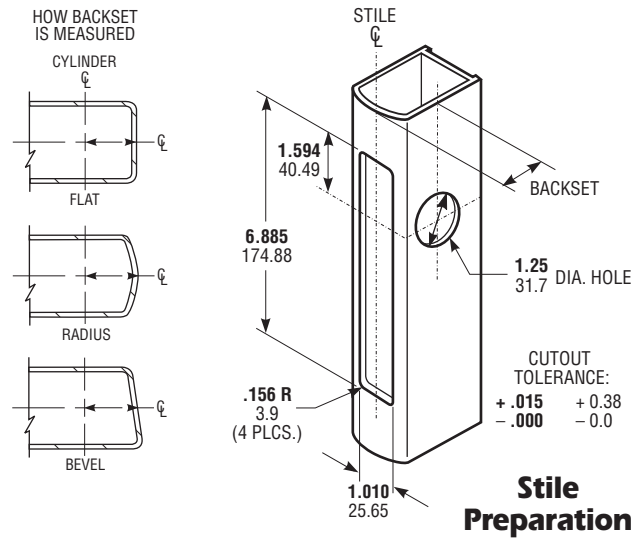

Stile Preparation

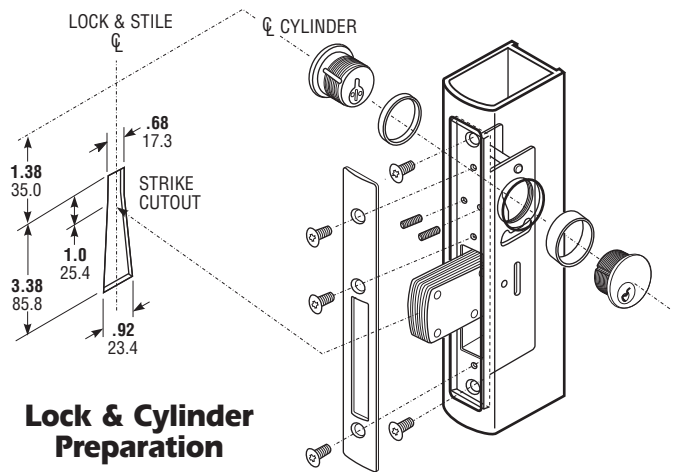

Lock & Cylinder Preparation

HOW TO ORDER

Specify quantity and the following information.
Order related hardware separately.

OPTIONS

For jambs too narrow to accept the long bolt, the MS1850S-050 offers a shorter bolt with hook shape to provide equal security against door-prying attempts. (See catalog page SL-1.) 1850S-020 short throw without hook also available. Second and third point locking bolts are available for pairs of doors. (See pages SW-10 and SW-11.) All use any make standard mortise cylinder and thus can be keyed into systems with other types of doors. "SCHOOLHOUSE" version, also available, is modified so that operation from inside is "unlock only." This lock is handed and must be specified LH or RH. Specify Series SCH 1850S. Same faceplate and backset options as Series MS1850S. Operation from inside, with standard Adams Rite 4066 Turn seen on page SW-33 or with 4550 Deadbolt Lever (page SW-15). For wood or hollow metal, see MS1850SN.

STANDARD PACKAGE

Individually boxed with machine screws for mounting. Cylinders and/or thumbturn available at extra cost. Shipping weight: 1-1/2 lbs.

Faceplate Shape	Backset	Handing
1850S Flat	2 31/32"	15 LH or RHR
1851S Radius	3 1-1/8"	16 RH or LHR
1851SW Radius w/w/strip	4 1-1/2"	10 Non-Handed*
1852S Bevel		

MS 1850S - 215 - 628

Finish	
628	Clear Anodized
313	Dark Bronze Anodized
335	Black Anodized

*Any flat or radius face, except Schoolhouse.